

PRODUCT SPECS

CENTRAL HEATING UNIT 900 CHU

FEATURES

- The 900 CHU is available in a diesel version, a gas version which operates on LP or NG and a Tri-fuel version which operates on diesel, LP or NG. Conversion from one fuel source is accomplished with a quick burner change-out.
- Conversion from one fuel source to another can be accomplished in as little as 15 minutes.
- Includes unique "Combustion Environment Control" system which ensures efficient and reliable burner operation in all conditions.
- Compact and portable design for easy positioning on the work site.
- All system operation is controlled and monitored from the central heating module control panel.
- 8-light system operating feature for easy system troubleshooting.
- Fluid circulation system is low pressure and atmospherically vented. There is no chance of an explosion or line burst due to pressure build-up. No special boiler certification is required to operate the system.
- Quick connect hose couplers, "no-drain" fluid lines and a "rapid air elimination" feature ensure a quick set-up and go operation.
- Conforms to most special job requirements due to its modular nature.

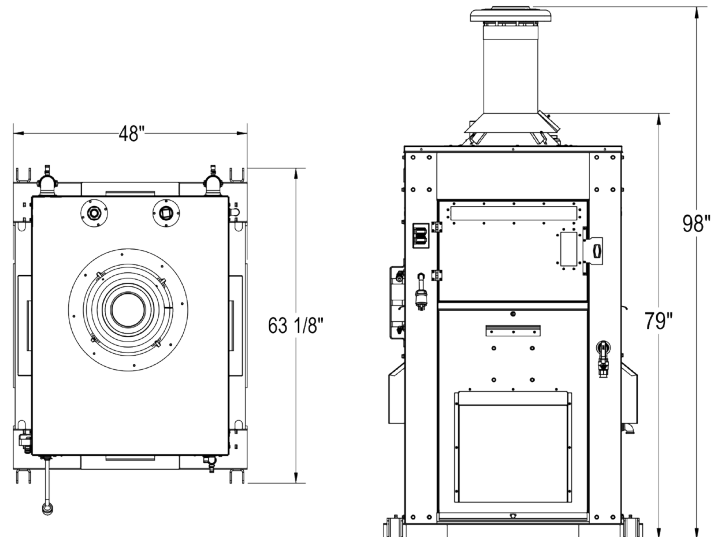

400 Service Road, St. Brieux, SK, S0K 3V0, Canada

1-888-750-1700 | WWW.DRYAIR.CA

PRODUCT SPECS

CENTRAL HEATING UNIT 900 CHU *cont'd*

SPECIFICATIONS

.....

Burners..... Two stage

Fluid Temperature

range 120°F to 180°F

Fluid volume.... 45 US gal

Fuel Specs:

Diesel

Input Capacity

- 896,000 Btu/h

Output Capacity

- 761,600 Btu/h
(29 hrs operating range
at full output)

Consumption (max)

- 6.4 US gph

Natural gas

Input Capacity

- 845,000 Btu/h

Output Capacity

- 676,000 Btu/h

Propane

Input Capacity

- 857,500 Btu/h

Output Capacity

- 686,000 Btu/h

Controls and monitoring:

Pump and temperature controls, full gauge panel showing circulation fluid temperatures and pressures, 8-light system operation feature for easy troubleshooting

Weight 2,800 lbs (dry)

..... 4,100 lbs (wet)

Electrical 115/230 V, single phase, 60 Hz, 30 A

Loading (standard):

Forklift pockets on both sides

Heat exchanger:

Robust water jacket/fire tube type

Combustion environment control system:

Maintains optimum fuel and combustion air temperatures; ensures system start-up and smooth, efficient and reliable operations in the widest range of conditions

Before system start-up

Pre-heater

- 4,000 W electric circulation heater, 230 V, preheats heat exchanger glycol before system start-up

During system operation

Diesel fuel heater

- Automatically maintains set fuel temperature

Combustion air heater

- Automatically maintains set combustion air temperature

Internal fluid circulation system:

Basic features

- Atmospherically vented low pressure system, single supply and return, adjustable fluid

(Basic features cont'd)

temperature control, auto pressure bypass for pump protection and variable flow demands, auto temperature bypass for heat exchanger protection

Heat transfer fluid (HTF)

- Non-toxic propylene glycol/water mixture

Primary lines and couplers

- 2" fluid circulation lines, 2" ball valves, 2" Kamlok® quick couplers

Circulation pump

- 2 hp, 80 US gpm @ 30 psi

Lock-out..... Locks out primary "supply" and "return" fluid circulation valves and control panel

Optional:

Lift frame

- Steel frame with corner lifting eyelets

Fuel conversion

- Diesel, propane and natural gas burners

Certification: UL/CSA certified

.....



400 Service Road, St. Brieux, SK, S0K 3V0, Canada

1-888-750-1700 | WWW.DRYAIR.CA